

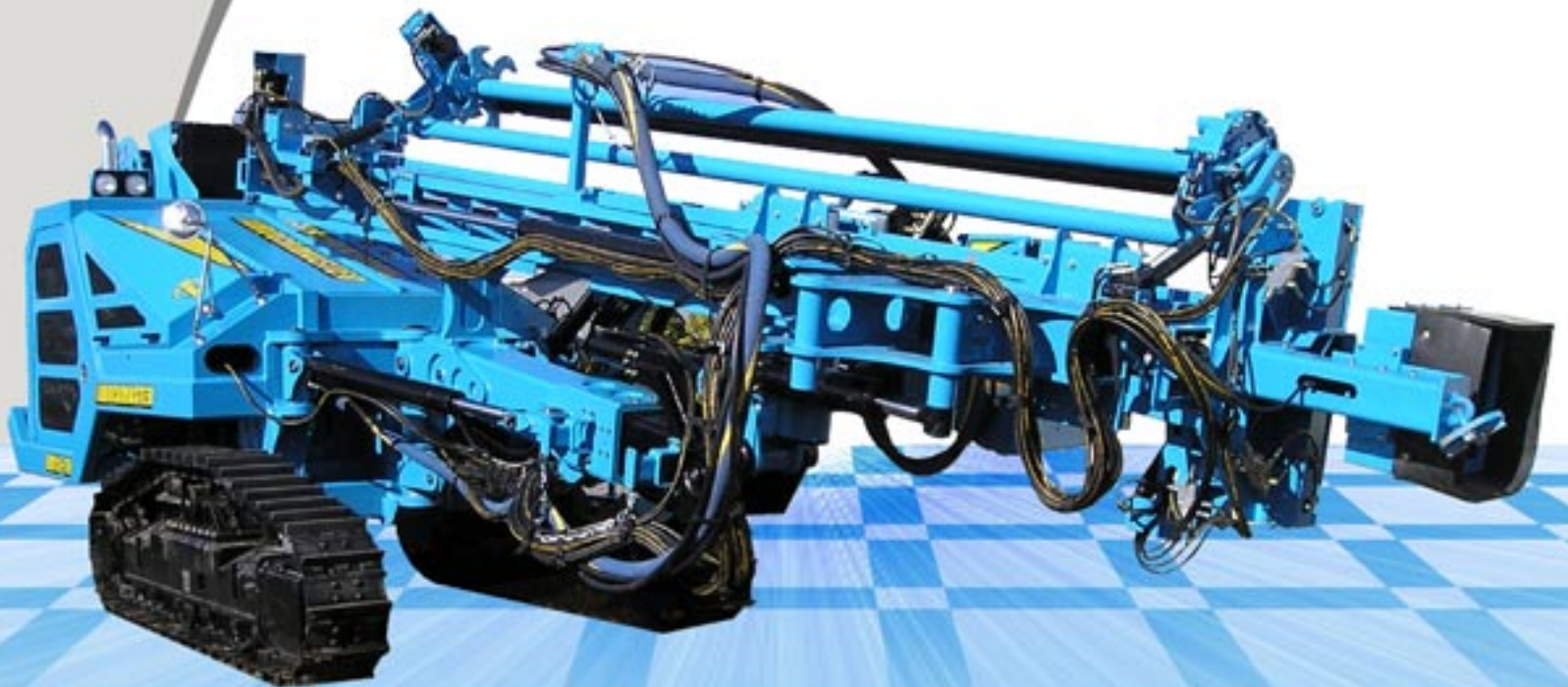

KOVAMAG

III ROCKMASTER



**VERSATILE 17H DRILL RIG FOR
SURFACE MINING**



ROCKMASTER



FINALLY...YOU HAVE A SOLID OPTION... A VERSATILE, HIGH PERFORMANCE DRILL RIG FOR SURFACE MINING...

SPECIAL FEATURES

Introducing the Novamac Rockmaster...The global rock drilling solution...

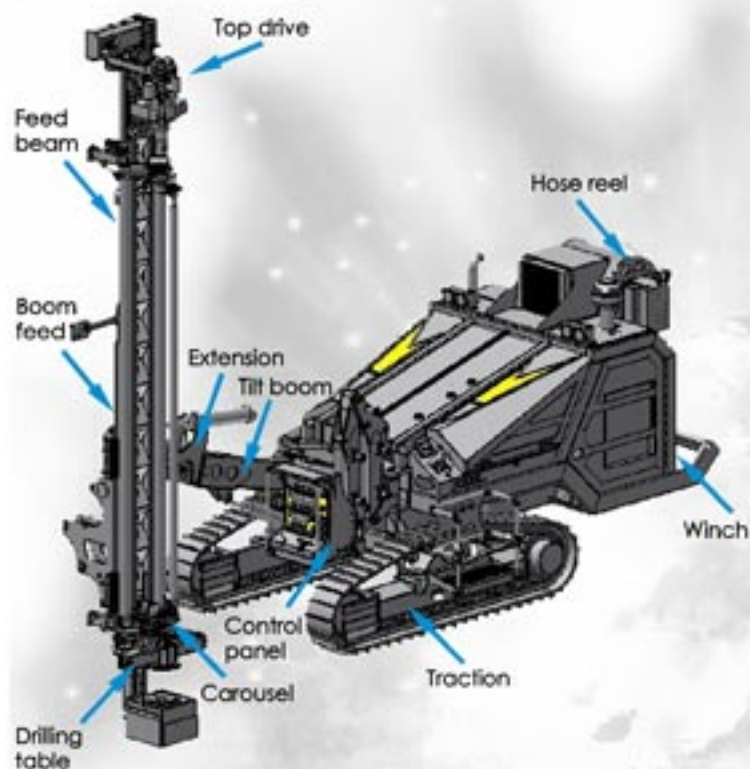

More versatile, more power and greater drilling performance achieved by enhanced movements of the boom...

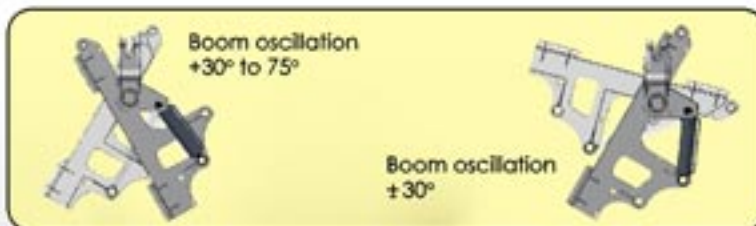
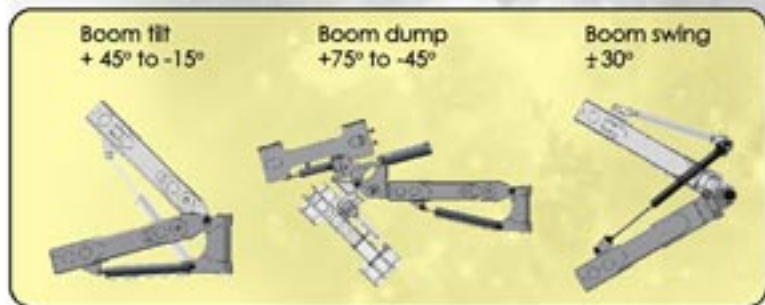

A RUGGED CHASSIS



The Rockmaster features a durably constructed chassis. A well designed structure is the key element to a long lasting drill rig. The unique design and construction of the Rockmaster chassis offers superior durability and maximum flexibility for maintenance.

TRACTION

A strong undercarriage track frame with independent oscillation ($\pm 10^\circ$) has been integrated to the structure permitting drilling in most rough terrains.



Improving stability with a flexible track frame.





ROCKMASTER

POWER AND TOUGHNESS...

SAFER WORKING ENVIRONMENT

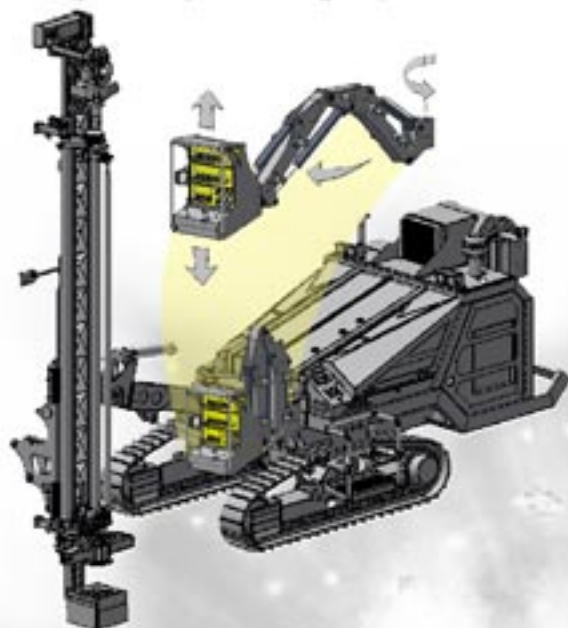

The fully hydraulic control panel is mounted on a ergonomically designed swing arm to offer an enhanced vision of the operations resulting in a safer environment.

HOSE REEL

Integrating the hose reel in a more convenient way!



An advanced, fully embedded hose reel.

WINCH

A powerful winch can be installed on demand.



Gain access to severe rock cliffs with a winch that has a pulling capability of 45 000 lbs (200 kN).

FEED MAST

From its unique conception, the Rockmaster feed system provides superior rigidity resulting in high drilling accuracy from 3 in (73 mm) to 8 3/4 in (222 mm). The ultra rigid feed beam has been specifically conceived to provide a long lasting drilling service.

An advanced, ultra rigid sheet metal plated feed boom minimizing deflections during drilling.



1 A strong hydraulic top drive mounted on an adjustable slide.



2 A powerful optional break-out system for smooth handling of the rods.



3 The flexible carousel can handle 6 steel rods. The cups can be mounted for several specifications of the rods.



4 A complete drill table including the pick-up pot, the drill rod centralizer, a hydraulically activated pipe wrench and an automatic greaser.





ROCKMASTER

Novamac Eurasia
 Ecocity Group
 3745 St-Jacques West Suite 226
 Montreal, Quebec, Canada
 H4C 1H3
 T : 1-514-798-2444
 F : 1-514-798-4905
 E : sales@ecocity-group.com

POWER AND TOUGHNESS...

HYDRAULIC SYSTEM

Primary pump	2 axial piston with variable displacement
Pressure/Flow	300 bar /41gpm (155,2L/min)
Auxiliary pump	1 gear pump of 15 gpm (56,8 L/min) / max pressure 200 bar
Filtration system	Fiberglass filter with 10 micron filtration

WATER INJECTION

Manufacturer	Cat pumps
Model	820
Type	Stainless steel piston pump
Pressure/flow	0-700 psi (0-4826 kPa) 0-9 gpm (0-34 L/min)
Revolution	0-800 rpm
Filtration system	40 micron

DRILLING SYSTEM

Torque capacity	5400 lbs-ft (7321 N-m)
Variable speed	0-60 rpm
Feed leaf-chain sys.	Hoisting and pull down force of 15 000 lbs (66 723 N)

ENGINE

Manufacturer	Cummins
Model	Electronic turbocharged diesel engine QSB4.5
Number of cylinders	4
Power	150 hp (113 kW) at 2300 rpm
Fuel consumption	2,67 U.S. gal/hr (11,2L/hr)
Filtration system	2 stages
Control panel	Integrated safety panel 24 Volts
Emission certification	U.S. EPA Tier 3, EU Stage III

ELECTRICAL

24 VDC
 Max current 60 A

DIMENSIONS AND WEIGHT

Weight : 39 000 lbs (17 690 kg)
 Ground clearance : 22 in (0.56 m)

Specifications subject to change without notice. Some items shown may be optional at extra cost.

